

CROSSFIRE

CAR AUDIO

C5 - SERIES



C5 - 500.2 | C5 - 400.4 | C5 - 800.4
C5 - 800D | C5 - 1600D

WWW.CROSSFIRECARAUDIO.COM

TABLE OF CONTENTS

IMPORTANT MESSAGE	1
FEATURES & SPECIFICATIONS	2-3
POWER, GROUND, REMOTE	4
SPEAKER OUTPUT & CONNECTING WIRES	5
WIRING CONFIGURATIONS	6-7
SINGLE INPUTS & STRAPPING	8-9
LOW LEVEL INPUT CONFIGURATIONS	10-11
IMPORTANT PRODUCT MESSAGE (MUST READ)	12
WARRANTY	13

PERSONAL RECORDS / CONTACT INFORMATION

For your records, Crossfire recommends keeping the model and serial number of your new Crossfire amplifier. This could possibly help you recover your amplifier in the event of theft. Use the following spaces to do so and make sure to keep your manual in a safe and dry place.

Model: _____

Serial Number: _____

Date of Purchase: _____

Place of Purchase: _____

Notes: _____

E-mail Contacts:

tech@crossfirecaraudio.com (technical support)

Address and Phone numbers:

756 Port America Place, Suite 100 Grapevine, TX, 76051

PH: (972) 570-0800 FX: (972) 570-2200

www.crossfirecaraudio.com

Thank You for choosing Crossfire! Enjoy the music!

IMPORTANT

PLEASE READ ALL INSTRUCTIONS BEFORE INSTALLING!

The quality of installation may affect the performance and reliability of your Crossfire product. If you have any doubts or questions regarding installation, we recommend that you contact your authorized Crossfire dealer. Remember to follow all wire and fuse requirements suggested in this manual. Warranty may void if proper installation technique is not used (refer to the warranty section in the rear of this manual).

MOUNTING

Appropriate mounting is very important for prolonged life expectancy of any amplifier. Select a location with ample space that allows sufficient airflow and provides protection from moisture. Keep in mind that an amplifier should never be mounted upside down. Upside down mounting will compromise heat dissipation through the heat sink and will engage the thermal protection circuit much sooner. Excessive heat can shorten your amplifier's life. To maximize heat dissipation, be sure to leave at least 2.5 inches of clearance around the amplifier. Fans should be used in correspondence with an escape duct for heat when mounting the amplifier in an enclosed or restricted area.

Avoid slipping and scratching your new Crossfire amplifier by pre-drilling the mounting holes with either an 1/8" or 3mm diameter drill bit when using the screws supplied in the accessory kit. Always investigate the mounting area thoroughly for electrical wires, vacuum lines, and brake or fuel lines before you start, as to prevent any potentially expensive mistakes.

Incorrect Mounting

Heat is trapped inside the amplifier, shortening the life of the electronic components.

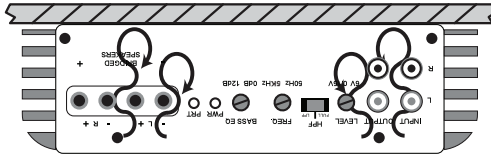

X WRONG!

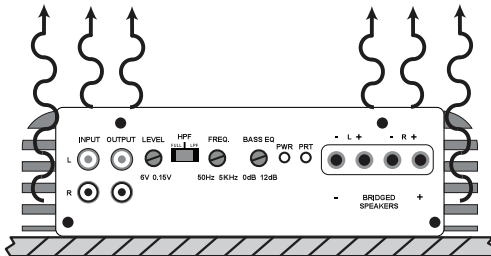

✓ CORRECT!

Correct Mounting

Heat is lifted from the amplifier heat sink.

CLASS A/B FEATURES

Fully 2 Ohm Stable Stereo Operation
Military Spec. Audiophile Grade Components
High Efficiency MOSFET Power Supplies
Multi-Stranded Power Torroid
Efficient Bipolar Output Transistors
Oversized Capacitor Bank
Nickel Plated Input and Output Connectors
Variable Highpass and Lowpass Electronic Crossovers
Simultaneous Mono/Stereo Operation Capability
Internally Bridgeable
5 Way Protection Circuitry
Soft Start, On/Off Circuitry

SPECIFICATIONS

	CS-500.2	CS-400.4	CS-800.4
RMS @ 4 Ohm (12.5v)	125W X 2	50W X 4	100W X 4
RMS @ 2 Ohm (12.5v)	250W X 2	100W X 4	200W X 4
Bridged @ 4 Ohm (12.5v)	500W X 1	200W X 2	400W X 2
LP/HP Crossover	50 - 5kHz	50 - 5kHz	50 - 5kHz
Line Output	YES	YES	YES
Fuse Rating	2 X 30 AMP	2 X 30 AMP	3 X 40 AMP
Internally Fused	YES	YES	YES
Dimensions: H = 2.4" W = 8.7", L =	14"	13.2"	16.4"
Dimensions: H = 60.5mm W = 202mm, L =	356mm	336mm	416mm

CLASS D FEATURES

1 Ohm Stable Mono Operation
Military Spec Audiophile Grade Components
High Efficiency PWM Power Supply
Multi-Stranded Power Torroid
Oversized Torroidial Core
MOSFET Input and Output Transistors
Oversized Capacitor Banks
Discrete Mount Power and Speaker Terminals
Variable Lowpass Electronic Crossover
Variable Subsonic Filter
RCA Preamp Output
Strappable
5 Way Protection Circuitry
Soft Remote On/Off Circuitry

SPECIFICATIONS

	CS - 800D	CS - 1600D
RMS @ 4 Ohm (12.5v)	350W X 1	700W X 1
RMS @ 2 Ohm (12.5v)	600W X 1	1200W X 1
RMS @ 1 Ohm (12.5v)	800W X 1	1600W X 1
LP/HP Crossover	40-150Hz	40-150Hz
Line Output	YES	YES
Strappable	YES	YES
Fuse Rating	100 AMP	180 AMP
Internally Fused	NO	NO
Dimensions: H = 2.4" W = 8.7", L =	11"	11.8"
Dimensions: H = 60.5mm W = 202mm, L =	280mm	300mm

POWER - GROUND - REMOTE

All Crossfire amplifiers work within 11 volts to 16 volts DC. Therefore, as a precaution, the vehicle's electrical system should be checked for correct voltage supply with the help of a voltmeter. First, connect the test leads of the voltmeter to the battery terminals with the ignition of the vehicle in the off position. The voltmeter should read no less than 12 volts. Next, check voltage of the battery with the engine running between 1500 and 2000 rpms. The voltmeter should now read between 13.5 and 14.5 volts. If your vehicle's electrical system is not up to these specifications, we recommend having it checked by an automotive mechanic before you further the installation.

POWER WIRE AND FUSE

The proper wire size is very important for an amplifier capable of these power levels. The following are the minimum recommended fuse values and wire gauge for lengths up to 20ft.

POWER

Power wires need to be connected directly to the battery using the wire requirements listed above. Never use the fuse box or any other wire as a source for the power for an amplifier. Before you start, choose the easiest and safest path to run the wire from the battery to the amplifier. Generally, try to keep the power wire on the driver's side of the vehicle (See Signal Inputs & Outputs for explanation). Follow the rules below for running the power cable through the vehicle:

1. Use grommets when passing the power wire through any metal wall of the vehicle.
2. Avoid sharp corners or sharp body parts that may easily cut through the insulation on the wire.
3. Avoid running the power wire over engine components and near heater cores.
4. Avoid the gas, brake and clutch pedals and their mechanisms.
5. Use an inline fuse at the battery to eliminate the risk of a fire caused by a short in your power wire.
6. Connect the fuse holder as close to the battery positive terminal as possible.

GROUND

The wire used for ground should be of the same gauge as the power wire. Make sure to choose a different color (generally black) so that you do not reverse the polarity at the amplifier terminals. Follow the rules below for connecting the ground wire properly:

1. Avoid using seat bolts, seatbelt bolts, and fender wells for ground.
2. Choose a metal area close to the amplifier that appears to be a good source of ground, such as the floor.
3. Investigate the area you wish to use for electrical wires, vacuum lines, and brake or fuel lines.

Directions for connecting the ground wire to the vehicle:

1. Find a nut and bolt to fit the ring terminal you have chosen.
2. Drill a hole just large enough for the bolt to fit through at the source of ground.
3. Use either a wire brush or sandpaper to eliminate unwanted paint around the hole you have drilled as to supply a better contact for your ground.
4. Terminate the ground wire to the ring terminal and attach it to the bare metal using the nut and bolt. It is very important for this connection to be solid.
5. Spread silicon over the screw and bare metal to prevent rust and possible water leaks.

REMOTE TURN-ON

Between the power and ground of the amplifier is a remote turn-on terminal. This terminal must be connected to a switched +12 volt source to make the amplifier operational. Typically, remote turn-on leads are provided at the head unit that will turn on and off the amplifier in correspondence with the source. This means you will most likely have to remove the head unit from the dash to find the source +12V output wire.

Once the head unit is pulled from the dash, find the remote turn-on located in the wiring harness of the head unit. The majority of vehicles will be using an after market head unit when installing an after market amplifier. These after market head units generally use a blue or blue/white colored wire as the remote turn-on lead. In most cases the blue/white lead is usually the remote turn on lead. However, when using a factory radio, the power antenna wire may be used as a turn-on lead. You must first test this lead to make sure that it remains energized regardless of the source the head unit is switched to. The antenna lead will energize when switched to the tuner mode, but turn off when the unit is switched to tape/CD player. Only if a lead is not available at the source, a switched +12 volt supply, such as a toggle switch should be applied. Use a minimum of 18-awg wire to connect the amplifier to this lead. Connect this lead to the head unit using a mating terminal or by soldering the three points together, but be sure to heat shrink the connection. If possible run this wire along side of the power wire using the same precautions.

SPEAKER OUTPUT

LOAD

Please be aware of the minimum impedance you may apply to your particular model amplifier. See chart below for more information. Any lower impedance than the minimum can send the amplifier into current protection or possibly damage the circuitry. To prevent damage, use the following formulas to help you figure out the load you are placing on your amplifier. If you have any difficulties, please contact your local Crossfire dealer or Crossfire's Technical Assistance at tech@crossfirecaraudio.com

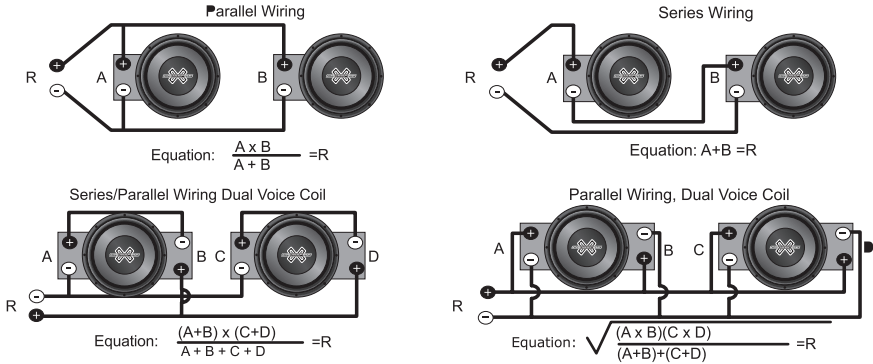

WIRING

Always choose speaker wire wisely. Make sure that the wire is appropriate for the speaker you are applying it to. It is highly recommended not to use anything smaller than 16awg. Consult your dealer. As with the power wires, use caution around sharp corners or body parts that may easily cut through the insulation on the wire. If running into the doors, it is important to use a protective boot in the door jam to protect the wire from being pinched as well as keeping water or moisture from entering the vehicle. Use the factory boots whenever possible. And always make sure the wire is out of the way of the window track. To connect the wire to the speaker, strip off approximately 1/2" inch (12mm) of the insulation and terminate the wires using insulated speaker terminals or by soldering the connection to the loudspeaker. Be sure that the polarity at the loudspeaker is correct.

CONNECTING THE WIRES

At this point, the power, ground, remote, and speaker wires should be run to the general location of where the amplifier is to be mounted. If the wires are to be hidden under the carpet, you now need to cut a slit for them to come through. To do this, place the amplifier in the location it is to be mounted to verify where the slits need to be. Make sure that there will not be a conflict with the mounting of the amplifier and the wires. Pull the wires through the slit to the terminals leaving approximately 6" (150mm) of slack and cut the wires to an equal length. Strip approximately 1/2" inch (12mm) of insulation from the end of each wire. Loosen the terminal screws on the amplifier. Insert the wires into the proper terminals and tighten the screws securely. Check your connections by giving the wires a slight tug.

2 CHANNEL WIRING CONFIGURATIONS

SINGLE CHANNEL OPERATION (BRIDGED)

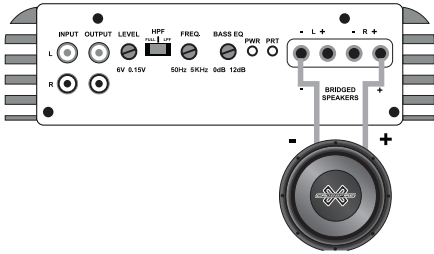

TWO CHANNEL OPERATION (STEREO)

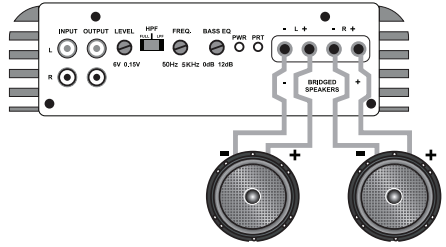

THREE CHANNEL OPERATION (STEREO / MONO)

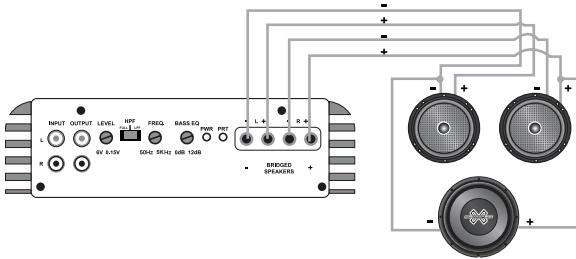

FOUR CHANNEL OPERATION (STEREO)

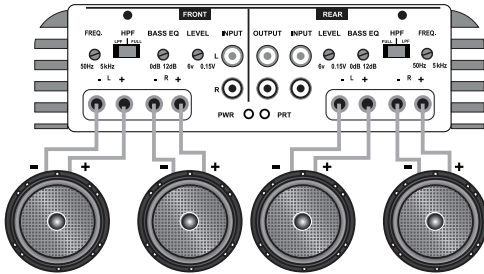

THREE CHANNEL OPERATION (STEREO & MONO)

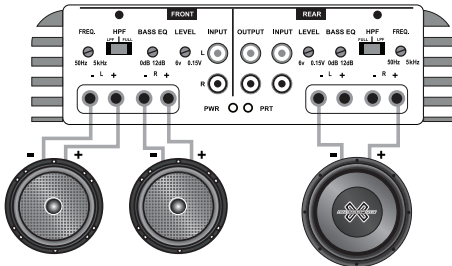

CLASS D WIRING CONFIGURATIONS

The Class D amplifiers are single channel amplifiers. Unlike Crossfire Class A/B amplifiers, these operate as single channel, therefore one amplifier cannot be bridged by itself. Please see diagram below.

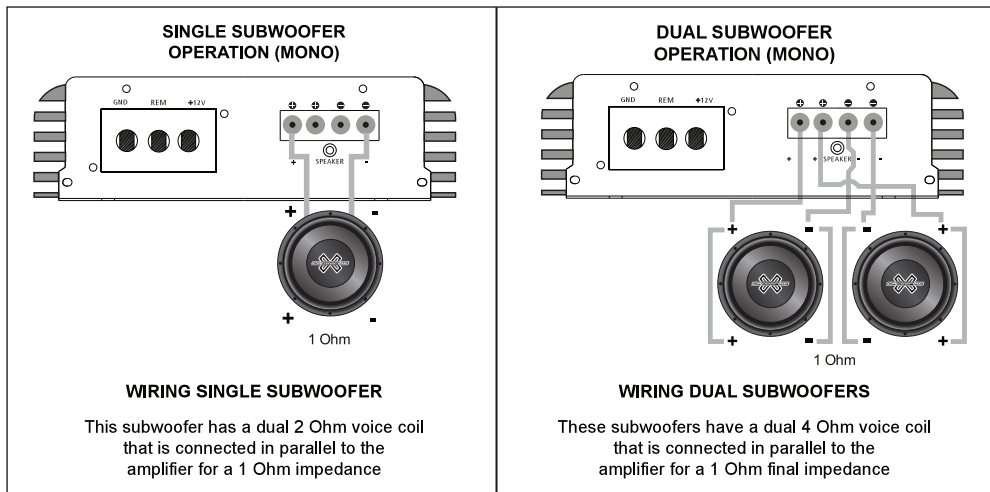

PREAMP FEATURES

CROSSOVER

On the side panel of your amplifier is a potentiometer marked 50Hz-250Hz on all Class A/B Amplifiers, 40Hz-150Hz on all Class D Amplifiers. This controls the relative crossover point for the amplifier. To apply the crossover feature, locate the switch on the same side panel that's labeled HPF/FULL/LPF. For highpass applications, such as componet sets or coaxials, choose HPF. For lowpass applications, such as woofers, choose LPF. If you are looking for full range application, place switch on FULL. Note that full will override the crossover completely. Class D Amplifiers come with low pass (LPF) function only.

Listed below are recommended crossover points for various size speakers. These are only guidelines. Actual crossover points recommended by the speaker manufacturers may vary and we suggest you follow those recomendations.

Speaker size Crossover recommendation:

4" (100mm) Component/ coaxial	HPF 130Hz - 150Hz
5.25 (130mm) Component/ coaxial	HPF 80Hz - 110Hz
6" (160mm) Component/ coaxial	HPF 70Hz - 100Hz
8" (200mm) woofer	LPF 90Hz - 120Hz
10" (250mm) subwoofer	LPF 70Hz - 100Hz
12" (300mm) subwoofer	LPF 70Hz - 100Hz
15" (380mm) subwoofer	LPF 50Hz - 80Hz

BASS EQ

If your system is lacking low bass response locate the **BASS EQ** dial on the amplifier. A boost from 0-12dB centered around 45Hz can be added by turning the dial clockwise. With the dial turned all the way counter clockwise 0 boost will be added. This boost function is available on specific models only. Please see specification chart for verification. Crossfire highly recommends using this feature only on amplifiers powering subwoofers.

SINGLE INPUTS

Getting a clear signal from the head unit to the amplifier is very important. To achieve this, the proper signal cables (RCA style) must be used. Estimate the length of the cables necessary. Take note that signal cable manufacturers will probably not have the exact length necessary for your vehicle. If you are between sizes, purchase the slightly longer cable. You can always hide the extra wire.

Be aware of the differences in cable. Better RCA's usually have multiple layers of shielding and/or twisted pair wiring for better noise rejection. Ask your local dealer for their recommendation.

LINE LEVEL INPUTS

Car environments are notorious for poorly insulated wires. This means that hiss, engine noise, and electrical noise can easily be picked up through RCA cables if ran incorrectly. To avoid inducing noise into the system, run the RCA's away from large wire looms and electric fans if possible. Always make sure to position your signal cables away from the power wire, preferably on the opposite side of the vehicle or at least 18" apart. When routing the power wire, use caution around sharp corners or body parts that may easily cut through the cables.

When connecting the signal cables, check the balance to the source unit and the amplifier. The cables should be marked: red is right and black or white is usually left. Once you have connected the signal cables to the head unit, slide the unit back into the dash. Make sure the unit is in securely.

HIGH LEVEL INPUTS

Please use a high quality line level convertor to convert the high level outputs from your headunit to low level signals

LEVEL CONTROL

Next to the preamp inputs on the side panel of the amplifier is the level control, commonly referred to as the gain. The gain allows you to match the output level of your source unit or signal processor to the input level of the amplifier. Matching the input can be accomplished in three simple steps:

1. Turn gain (level) control to minimum.
2. Turn on the source unit and adjust to 2/3 of max volume while playing music.
3. Adjust the gain control until desired, maximum volume is achieved without audible distortion.

Remember that the gain control is not a volume knob. Ignoring the three steps above may leave you with damaged speakers and possibly damaged amplifier(s).

STRAPPING TWO AMPLIFIERS TOGETHER

"Strapping" Two amplifiers together

Strapping two like amplifiers together is fairly easy. Study the following instructions as well as the diagrams below to assure proper connections. If you experience any difficulties, please contact Crossfire's Technical Assistance at tech@crossfirecaraudio.com

STRAPPING CIRCUIT (Invert output)

The internal strapping module can only be used when a pair of either C5-800D or C5-1600D are used. Strapping allows for the two amplifiers to be run in series and achieve double the output into one load. However, this does change the minimum impedance stability to 2 ohms. Strapping the amplifiers should only be done if the proper impedance cannot be achieved with the amplifiers separated.

It is very important to set the Master/Slave control on the amplifier whether you are strapping or not. If the settings are in the wrong position, the amplifier(s) may not work. There are two settings for this control: Master and Slave. Use the following to determine what position to set your amplifier(s) in.

Master: this setting will maintain the same phase as the signal applied to it.

1. Use this setting if the amplifier is not bridged with another amplifier.
2. When strapping the amplifiers, use this setting only on the amplifier that is connected to the head unit.

Slave: this setting limits the controls of the secondary amplifier in a strapped pair.

1. All crossover, subsonic and level controls of this amplifier will be bypassed. The amplifier set on Master will then control all the preamp functions for both amplifiers.

SUBSONIC FILTER

The subsonic filter is used to reduce the amount of low frequency harmonics and/or subsonic noise picked up in audio systems. Both of these can be damaging to subwoofers and possibly the amplifier(s). As well, harmonics and subsonic noise can cause the amplifier(s) to pull excess power from your electrical system.

This filter is variable on all Class D Amplifiers and is variable from 15Hz to 40Hz. So what frequency should you set the subsonic filter at? For most applications it is desirable to leave this between 15Hz and 30Hz. If you are using a ported enclosure designed for SPL, yet you are using the system on a daily basis, a higher filter frequency may be desired. This will allow the enclosure to be tuned higher and reduce the chance of the woofer to become non-linear and destroy itself.

Please review the following drawings for further reference.

STRAPPING SETTINGS AND WIRING

From Source

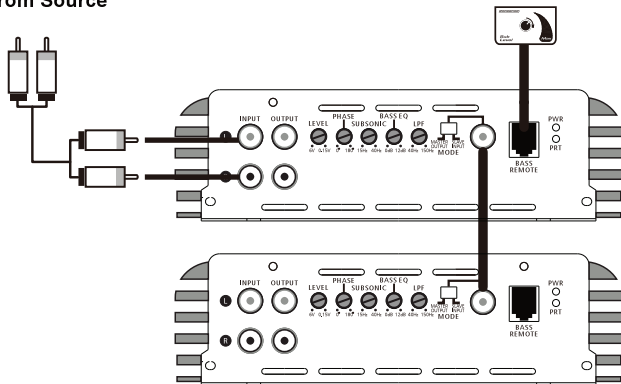

All Preamp functions of the slave amplifier are non-functional. The Master amplifier controls all level and crossover functions.

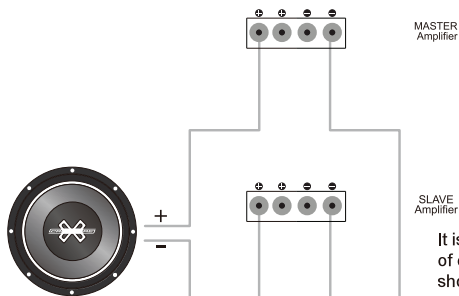

MASTER Amplifier

SLAVE Amplifier

It is very important that a negative of each amplifier is connected as shown.

LOW LEVEL INPUT CONFIGURATIONS CLASS A/B

Please note that your amplifier may differ from those shown on this page. The following page has additional model amplifiers and connection diagrams and configurations.

2 CH. CONFIGURATION

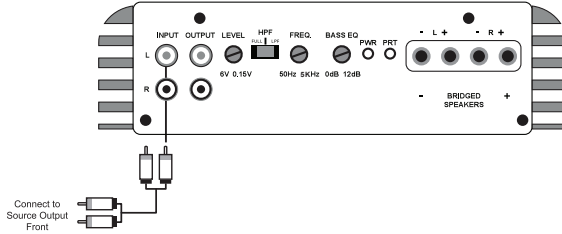

4 CH. WITH (1) RCA INPUT CONFIGURATION

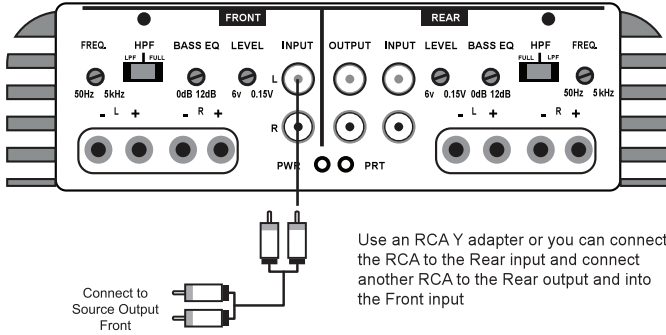

4 CH. WITH (2) RCA INPUTS CONFIGURATION

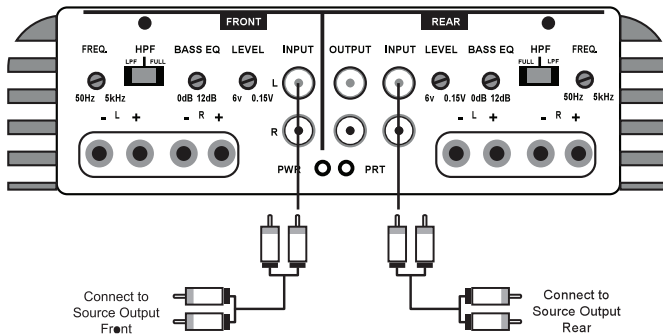

LOW LEVEL INPUT CONFIGURATIONS CLASS D

Please note that your amplifier may differ from those shown on this page.

SINGLE AMPLIFIER CONFIGURATION

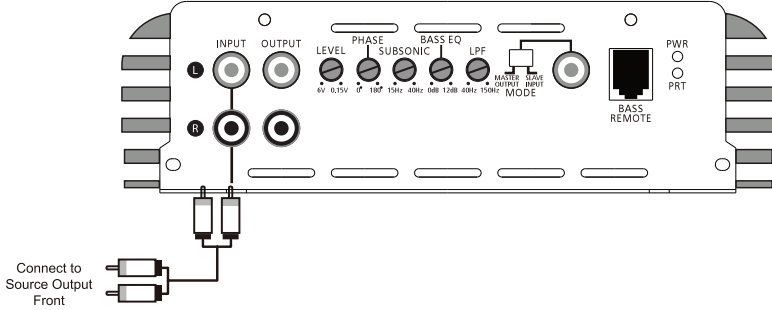

DUAL AMPLIFIER CONFIGURATION (Using 2 Amplifiers)

This example shows how to use 1 single pre-amp output to run dual amplifiers by using the RCA output provided by the Crossfire Class D amplifiers.

From Source

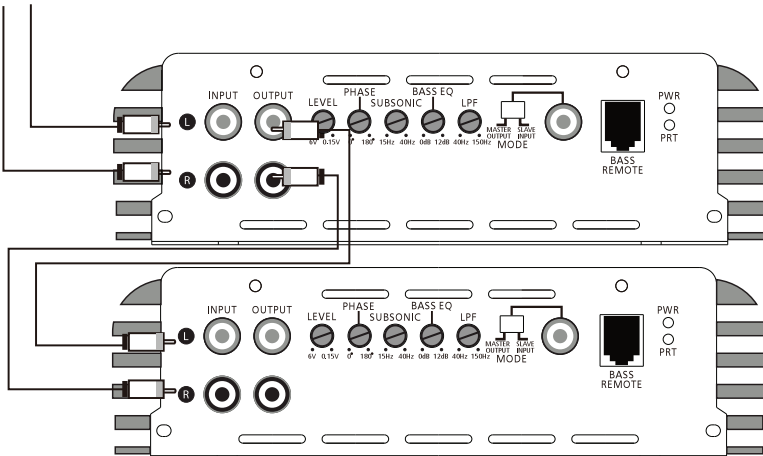

IMPORTANT!!

The majority of failures seen with Class D amplifiers are due to people using them in vehicles without the proper electrical considerations. The common misconception about Class D amplifiers contributes to this problem, since the C5-800D is a Class D amplifier and very efficient, the misconception is that it doesn't pull huge amounts of current. This is partly true, a C5-800D is capable of drawing 100 amps of current at max draw. At 100 amps of current to produce over 1000 watts is very efficient, while some class A/B amplifiers need over 200 amps to produce the same power.

We at Crossfire strongly suggest using one dedicated high quality battery per C5-800D or two batteries per C5-1600D amplifier. We also recommend upgrading the vehicles alternator whenever possible.

It is very important to keep your battery voltage above 12 volts and as close to 14.4 volts as possible. Not only do you get more power at 14.4 volts but you are risking serious damage to your amplifier below 12 volts. Ohms law states that current equals power (watts) divided by voltage. This means that current and voltage are inversely proportional, in other words as your battery voltage falls your amplifier has to draw more current to make the same amount of power. At a certain point the amp draws so much current that damages components in the input section. This is very common in all Class D amplifiers. The solution is to keep your battery voltage between 12 volts and 14.4 volts. If you follow the tips below you will get the best of most reliable performance from your C5 Amplifiers.

REMEMBER !!

1. Make sure the automobile has an electrical system that will support the audio systems current draw.
2. Upgrading your alternator for multiple amplifiers is recommended.
3. Use at least one (1) high quality battery per C5-800D or two batteries for C5-1600D.
4. For runs of 20ft or less use at least one 4 awg power wire and one 4 awg ground wire per C5-800D, 1/0 awg for C5-1600D. If you are using one wire with a distribution block for multiple amps, make sure to use a larger gauge wire for the main feed.
5. Be sure to test battery voltage at the amplifier terminals while the system is playing at high volume. Make sure this reading stays as close to 14.4 volts as possible, if this measure is below 12 volts see above tips or email Crossfire Technical Support at tech@crossfirecaraudio.com.

CROSSFIRE LIMITED WARRANTY

This warranty gives you specific legal rights, and you may also have other rights, which vary from state to state. This warranty is only valid on Crossfire products purchased in the U.S.A. from an authorized Crossfire dealer. All Crossfire amplifiers and speakers are warranted to be free from defects in materials and workmanship under normal use and service for a period of (1) year when the unit is installed by an authorized Crossfire dealer. Non-authorized dealer installed products carry a (90) days parts and labor limited warranty. The extent and conditions of Crossfire's limited warranty are as follows:

- i. Crossfire will either repair or replace (as its option) any unit which Crossfire has examined and found to be defective and under warranty, to the original purchaser, provided the defect occurs within (1) year of the date of purchase when installed by an authorized Crossfire dealer. This warranty includes both parts and labor and applies to the original purchaser only.
- ii. Crossfire will either repair or replace (at its option) any unit which Crossfire has examined and found to be defective and under warranty, to the original purchaser, provided the defect occurs within (90) days of the date of purchase when the unit is installed by a non-authorized Crossfire dealer. This (90) days warranty includes both parts and labor and applies to the original purchaser only.
- iii. This warranty will be void to any unit found with the original serial number removed, altered or defaced. All units received by Crossfire for warranty with their original serial numbers removed will not be repaired and will be returned to the sender freight collect.
- iv. The provisions of this warranty shall not apply to products used for any industrial, professional or commercial purposes or any other uses for which it was not designed or intended.
- v. This warranty does not cover cost for removal of product for repair or reinstallation of product after repair, nor does it cover the cost of returning the product to Crossfire's service center for repair.
- vi. This warranty does not apply to repairs or replacements necessitated by any cause beyond the control of Crossfire. Including, but not limited to, any malfunction, defect or failure caused by or resulting from unauthorized service or parts, improper maintenance, operation contrary to furnished instructions, shipping or transit accidents, incorrect power line voltages, fire, flood or any other acts of nature, or normal wear and tear.
- vii. The foregoing is in lieu of other expressed warranties and Crossfire does not assume or authorize any party to assume for it any other obligation or liability. The durations of any warranties, which may be implied by law (including the warranties of merchantability and fitness), is limited to the term of this warranty. In no event shall Crossfire be liable for special, incidental or consequential damages arising from obligations under this warranty due to cause beyond its control. Some states do not allow limitations on how long an implied warranty lasts and/or do not allow the exclusions or limitation of consequential damages, so the above limitations and exclusions may not apply to you.

viii. Return Policy.

Your unit will be serviced free of charge on an in-warranty basis only. If improper operation occurs, contact your authorized Crossfire dealer for assistance with the return and factory repair of your Crossfire product. If an authorized Crossfire dealer is not available, the following procedure must be followed: phone us at (972) 570-0800 or fax in your name, address, telephone number and the model number of the item(s) to be returned to receive a Return Authorization Number to (972) 570-2200. Your return authorization number must be clearly written on the outside of the packing box returned to Crossfire. All returned products must be accompanied with a dated proof of purchase invoice or the product may be subject to costs of parts and labor. Return the unit in the original protective carton or a carton with ample protection. Please include a brief description of the problem and send your repair to:



756 Port America Place, Suite 100 Grapevine, TX. 76051
PH: (972) 570-0800 FX: (972) 570-2200
www.crossfirecaraudio.com

STILL
LOUDER!



756 Port America Place, Suite 100 Grapevine, TX. 76051
PH: (972) 570-0800 FX: (972) 570-2200
www.crossfirecaraudio.com