

CROSSFIRE

XC215

SUBWOOFER

Official Owners Manual

Specifications

Driver Description	15" Subwoofer, Dual Voice Coil
Mounting Depth (in/mm)	8.4375/214
Cutout Diameter (in/mm)	14.125/359
Woofer Outer Diameter (in/mm)	15.375/391
Woofer Displacement (cu.ft./ltr)	.192/5.44
Impedance	Dual 1.8 ohm
Nominal Power Handling (RMS)	1500 watts
Maximum Power Handling (PE)	2500 watts
Dynamic Power Handling	4000 watts
Voice Coil Size	3" 4-layer all aluminum
Magnet Weight	240 oz.
Frequency Response	22-250Hz
Resonant Frequency (fs)	22.8Hz
Qts	.322
Qms	4.068
Qes	.350
VAS (cu. ft./ltr)	4.31/122.05
Efficiency (2.83V/1M)	88.6 dB

Power Ratings - Rating the power handling of subwoofers is not a difficult task. However, understanding power ratings is often confusing. Many times the Maximum Power Ratings are viewed as the RMS power handling of the driver, when in actuality Maximum is generally the breaking point of the driver. This has lead Crossfire to come up with a system rating the power necessary to drive our subwoofers. Please read the following cautiously before choosing your amplifier.

Nominal power handling - Nominal power handling is the power rating given by Crossfire at which the subwoofer will experience minimal mechanical degradation over time when using a recommended enclosure. In other words, this is the recommended power to be used per woofer to assure long life.

Maximum power handling (PE) - Maximum power handling is the power rating given by Crossfire at which the subwoofer could experience a high amount of mechanical degradation that may lead to possible failure over time when using the recommended enclosure. In other words, do not exceed this power level for extended periods of time.

Dynamic power handling - Dynamic power handling is the power rating given by Crossfire for peak transients and short bursts. Continuous playing at or above this level will cause mechanical failure and/or thermal failure. In other words, this power level should never be attained with the exceptions of approved SPL competition vehicles. This could possibly void your warranty.

Optimum Sealed Volume

Internal Volume: 1.4cu.ft/39.5ltr
 Enclosure "Q": .6
 -3dB response: 47Hz
 Maximum Power Handling: 1500 watts

Dimensions include woofer displacement compensation.

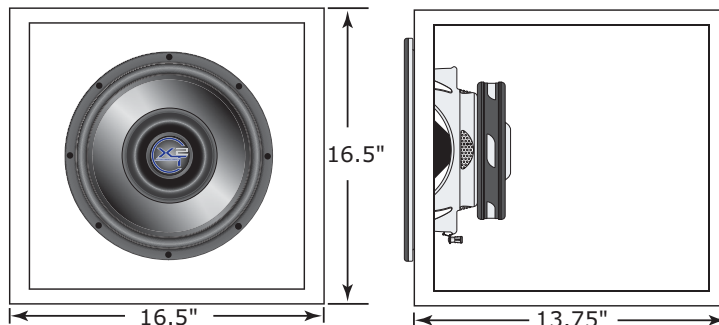

Cu. Ft./Liters	"Q"	-3dB	Max Power Handling
small sealed 1/28.3	1	53Hz	1500 watts
large sealed 2/56.5	.9	43Hz	1500 watts

Optimum Vented Volume

Internal Volume: 3.5cu.ft/99ltr
 Tuning Frequency: 36Hz
 Port (Area x L) 30 sq. in. x 14"
 -3dB response: 24Hz
 Maximum Power Handling: 1500 watts

Dimensions include woofer displacement, but DO NOT include port displacement.

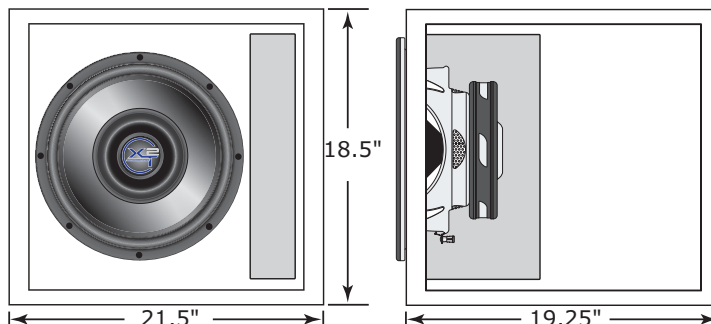

Cu. Ft./Liters	Tuned to	-3dB	Port Dimensions	Max Power Handling (PE)
small vented 3/85	40Hz	31Hz	25 sq. in. x 10"	1500 watts
large vented 4.5/127.5	41Hz	22Hz	30 sq. in. x 6"	1500 watts

NOTE: Dimensions for recommended enclosures are with considerations of using .75" (19mm) MDF board. Be sure to add .192cu.ft./5.5L for driver displacement. In addition, port displacement needs to be added for all ported enclosures. Crossfire's optimum recommended enclosures include woofer displacement, but DO NOT include port displacement.

CROSSFIRE LIMITED WARRANTY

This warranty gives you specific legal rights, and you may also have other rights which vary from state to state. This warranty is only valid on Crossfire products purchased in the U.S.A. from an authorized Crossfire dealer. All Crossfire products are warranted to be free from defects in materials and workmanship under normal use and serviced for a period of (3) years when the unit is installed by an authorized Crossfire dealer. Non-authorized dealer installed products carry a (1) year parts and labor limited warranty. The extent and conditions of Crossfire's limited warranty are as follows:

- i. Crossfire will either repair or replace (at its option) any unit which Crossfire has examined and found to be defective and under warranty, to the original purchaser, provided the defect occurs within (3) years of the date of purchase when the unit is installed by an authorized Crossfire dealer. This warranty includes both parts and labor and applies to the original purchaser only.
- ii. Crossfire will either repair or replace (at its option) any unit which Crossfire has examined and found to be defective and under warranty, to the original purchaser, provided the defect occurs within (1) year of the date of purchase when the unit is installed by a non-authorized Crossfire dealer. This (1) year warranty includes both parts and labor and applies to the original purchaser only.
- iii. This warranty will be void to any unit found with the original factory serial number removed, altered or defaced. All units received by Crossfire for warranty with their original serial numbers removed will not be repaired and returned to sender freight collect.
- iv. The provisions of this warranty shall not apply to products used for any industrial, professional or commercial purposes or any other uses for which it was not designed.
- v. This warranty does not cover costs for removal of product for repair or reinstallation of the product after repair, nor does it cover the cost of returning the product to Crossfire's service center for repair.
- vi. This warranty does not apply to repairs or replacements necessitated by any cause beyond the control of Crossfire. Including, but not limited to, any malfunction, defect or failure caused by or resulting from unauthorized service or parts, improper maintenance, operation contrary to furnished instructions, shipping or transit accidents, incorrect power line voltages, fire, flood or any other acts of nature, or normal wear and tear.
- vii. The foregoing is in lieu of all other expressed warranties and Crossfire does not assume or authorize any party to assume for it any other obligation or liability. The duration of any warranties which may be implied by law (including the warranties of merchantability and fitness) is limited to the term of this warranty. In no event shall Crossfire be liable for special, incidental or consequential damages arising from obligations under this warranty due to causes beyond its control. Some states do not allow limitations on how long an implied warranty lasts and/or do not allow the exclusions or limitation of consequential damages, so the above limitations and exclusions may not apply to you.

viii. RETURN POLICY

Your unit will be serviced free of charge on an in-warranty basis only. If improper operation occurs, contact your authorized Crossfire dealer for assistance with the return and factory repair of your Crossfire product. If an authorized Crossfire dealer is not available, the following procedure must be followed: phone us at (562) 906-0800 or fax in your name, address, telephone number and the model number of the item(s) to be returned to receive a Return Authorized Number to (562) 941-2294. Your return authorization number must be clearly written on the outside of the packing box returned to Crossfire. All returned products MUST BE accompanied with a DATED proof of purchase invoice or the product may be subject to costs of parts and labor. Return the unit in the original protective carton or a carton with ample protection. Please include a brief description of the problem and send your repair to:

12222 Bell Ranch Dr.
 Santa Fe Springs, CA 90670
 PH: 562.906.0800 FX: 562.941.2294
 www.CROSSFIRECARAUDIO.com